

Notice for TAIYO YUDEN products

Please read this notice before using the TAIYO YUDEN products.

⚠️ REMINDERS

■ Product Information in this Catalog

Product information in this catalog is as of January 2021. All of the contents specified herein and production status of the products listed in this catalog are subject to change without notice due to technical improvement of our products, etc. Therefore, please check for the latest information carefully before practical application or use of our products.

Please note that TAIYO YUDEN shall not be in any way responsible for any damages and defects in products or equipment incorporating our products, which are caused under the conditions other than those specified in this catalog or individual product specification sheets.

■ Approval of Product Specifications

Please contact TAIYO YUDEN for further details of product specifications as the individual product specification sheets are available. When using our products, please be sure to approve our product specifications or make a written agreement on the product specification with TAIYO YUDEN in advance.

■ Pre-Evaluation in the Actual Equipment and Conditions

Please conduct validation and verification of our products in actual conditions of mounting and operating environment before using our products.

■ Limited Application

1. Equipment Intended for Use

The products listed in this catalog are intended for general-purpose and standard use in general electronic equipment (e.g., AV equipment, OA equipment, home electric appliances, office equipment, information and communication equipment including, without limitation, mobile phone, and PC) and other equipment specified in this catalog or the individual product specification sheets.

TAIYO YUDEN has the line-up of the products intended for use in automotive electronic equipment, telecommunications infrastructure and industrial equipment, or medical devices classified as GHTF Classes A to C (Japan Classes I to III). Therefore, when using our products for these equipment, please check available applications specified in this catalog or the individual product specification sheets and use the corresponding products.

2. Equipment Requiring Inquiry

Please be sure to contact TAIYO YUDEN for further information before using the products listed in this catalog for the following equipment (excluding intended equipment as specified in this catalog or the individual product specification sheets) which may cause loss of human life, bodily injury, serious property damage and/or serious public impact due to a failure or defect of the products and/or malfunction attributed thereto.

- (1) Transportation equipment (automotive powertrain control system, train control system, and ship control system, etc.)
- (2) Traffic signal equipment
- (3) Disaster prevention equipment, crime prevention equipment
- (4) Medical devices classified as GHTF Class C (Japan Class III)
- (5) Highly public information network equipment, data-processing equipment (telephone exchange, and base station, etc.)
- (6) Any other equipment requiring high levels of quality and/or reliability equal to the equipment listed above

3. Equipment Prohibited for Use

Please do not incorporate our products into the following equipment requiring extremely high levels of safety and/or reliability.

- (1) Aerospace equipment (artificial satellite, rocket, etc.)
- (2) Aviation equipment *¹
- (3) Medical devices classified as GHTF Class D (Japan Class IV), implantable medical devices *²

- (4) Power generation control equipment (nuclear power, hydroelectric power, thermal power plant control system, etc.)
- (5) Undersea equipment (submarine repeating equipment, underwater work equipment, etc.)
- (6) Military equipment
- (7) Any other equipment requiring extremely high levels of safety and/or reliability equal to the equipment listed above

*Notes:

1. There is a possibility that our products can be used only for aviation equipment that does not directly affect the safe operation of aircraft (e.g., in-flight entertainment, cabin light, electric seat, cooking equipment) if such use meets requirements specified separately by TAIYO YUDEN. Please be sure to contact TAIYO YUDEN for further information before using our products for such aviation equipment.
2. Implantable medical devices contain not only internal unit which is implanted in a body, but also external unit which is connected to the internal unit.

4. Limitation of Liability

Please note that unless you obtain prior written consent of TAIYO YUDEN, TAIYO YUDEN shall not be in any way responsible for any damages incurred by you or third parties arising from use of the products listed in this catalog for any equipment that is not intended for use by TAIYO YUDEN, or any equipment requiring inquiry to TAIYO YUDEN or prohibited for use by TAIYO YUDEN as described above.

■ Safety Design

When using our products for high safety and/or reliability-required equipment or circuits, please fully perform safety and/or reliability evaluation. In addition, please install (i) systems equipped with a protection circuit and a protection device and/or (ii) systems equipped with a redundant circuit or other system to prevent an unsafe status in the event of a single fault for a failsafe design to ensure safety.

■ Intellectual Property Rights

Information contained in this catalog is intended to convey examples of typical performances and/or applications of our products and is not intended to make any warranty with respect to the intellectual property rights or any other related rights of TAIYO YUDEN or any third parties nor grant any license under such rights.

■ Limited Warranty

Please note that the scope of warranty for our products is limited to the delivered our products themselves and TAIYO YUDEN shall not be in any way responsible for any damages resulting from a failure or defect in our products. Notwithstanding the foregoing, if there is a written agreement (e.g., supply and purchase agreement, quality assurance agreement) signed by TAIYO YUDEN and your company, TAIYO YUDEN will warrant our products in accordance with such agreement.

■ TAIYO YUDEN's Official Sales Channel

The contents of this catalog are applicable to our products which are purchased from our sales offices or authorized distributors (hereinafter "TAIYO YUDEN's official sales channel"). Please note that the contents of this catalog are not applicable to our products purchased from any seller other than TAIYO YUDEN's official sales channel.

■ Caution for Export

Some of our products listed in this catalog may require specific procedures for export according to "U.S. Export Administration Regulations", "Foreign Exchange and Foreign Trade Control Law" of Japan, and other applicable regulations. Should you have any questions on this matter, please contact our sales staff.

▶ This catalog contains the typical specification only due to the limitation of space. When you consider the purchase of our products, please check our product specification sheets. For details of each product (characteristics graph, reliability information, precautions for use, and so on), see our website (<http://www.ty-top.com/>).

Automotive Application Guide

We classify automotive electronic equipment into the following four application categories and set usable application categories for each of our products. When using our products for automotive electronic equipment, please be sure to check such application categories and use our products accordingly. Should you have any questions on this matter, please contact us.

Category	Automotive Electronic Equipment (Typical Example)
POWERTRAIN	<ul style="list-style-type: none"> • Engine ECU (Electronically Controlled Fuel Injector) • Cruise Control Unit • 4WS (4 Wheel Steering) • Transmission • Power Steering • HEV/PHV/EV Core Control (Battery, Inverter, DC-DC) • Automotive Locator (Car location information providing device), etc.
SAFETY	<ul style="list-style-type: none"> • ABS (Anti-Lock Brake System) • ESC (Electronic Stability Control) • Airbag • ADAS (Equipment that directly controls running, turning and stopping), etc.
BODY & CHASSIS	<ul style="list-style-type: none"> • Wiper • Automatic Door • Power Window • Keyless Entry System • Electric Door Mirror • Automobile Digital Mirror • Interior Lighting • Automobile Air Conditioning System • LED Headlight • TPMS (Tire Pressure Monitoring System) • Anti-Theft Device (Immobilizer), etc.
INFOTAINMENT	<ul style="list-style-type: none"> • Car Infotainment System • ITS/Telematics System • Instrument Cluster • ADAS (Sensor, Equipment that is not interlocked with safety equipment or powertrain) • Dashcam (genuine products for automotive manufacturer), etc.

METAL MULTILAYER CHIP POWER INDUCTORS (MCOIL™ MC SERIES)

REFLOW

AEC-Q200

■ PARTS NUMBER

* Operating Temp.: -40~+125°C(Including self-generated heat)

M	C	K	K	2	0	1	2	T	1	R	0	M	V	C
①	②	③	④	⑤	⑥	⑦	⑧							

△=Blank space

① Series name

Code	Series name
MC	Metal base multilayer chip power inductor

② Thickness

Code	Thickness [mm]
KK	1.0 max

③ Dimensions (L × W)

Code	Type (inch)	Dimensions (L × W) [mm]
1608	1608 (0603)	1.6 × 0.8
2012	2012 (0805)	2.0 × 1.25

④ Packaging

Code	Packaging
T	Taping

⑤ Nominal inductance

Code (example)	Nominal inductance [μH]
R47	0.47
1R0	1.0

※R=Decimal point

⑥ Inductance tolerance

Code	Inductance tolerance
M	±20%

⑦ Internal code

Code	Special code1
V	MLCI for Automotive
8	MLCI for Telecommunications infrastructure and Industrial equipment / Medical devices

⑧ Special code

Code	Special code
C	Polarity Marking

■ STANDARD EXTERNAL DIMENSIONS / STANDARD QUANTITY

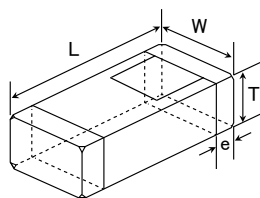

Type	L	W	T	e	Standard quantity [pcs]	
					Paper tape	Embossed tape
MCKK1608 (0603)	1.6±0.2 (0.063±0.008)	0.8±0.2 (0.031±0.008)	1.0 max (0.039 max)	0.3±0.2 (0.012±0.008)	—	3000
MCKK2012 (0805)	2.0±0.2 (0.079±0.008)	1.25±0.2 (0.049±0.008)	1.0 max (0.039 max)	0.5±0.3 (0.02±0.012)	—	3000

Unit: mm (inch)

INDUCTORS

AUTO

For Automotive Electronic Equipment
METAL MULTILAYER CHIP POWER INDUCTORS (MCOIL™ MC SERIES)

► This catalog contains the typical specification only due to the limitation of space. When you consider the purchase of our products, please check our product specification sheets. For details of each product (characteristics graph, reliability information, precautions for use, and so on), see our website (<http://www.ty-top.com/>).

PARTS NUMBER

• All the Metal Multilayer Chip Power Inductors of the catalog lineup are RoHS compliant.

Notes)

- The exchange of individual specifications is necessary depending on your application and/or circuit condition. Please contact TAIYO YUDEN's official sales channel.
- For Automotive (AEC-Q200 Qualified) products for BODY & CHASSIS, and INFOTAINMENT. Please check "Automotive Application Guide" for further details before using the products.
 < **AEC-Q200** : AEC-Q200 qualified >
 All the Metal Multilayer Chip Power Inductors for Automotive products are tested based on the test conditions and methods defined in AEC-Q200 by family item.
 Please consult with TAIYO YUDEN's official sales channel for the details of the product specifications and AEC-Q200 test results, etc.,
 and please review and approve the product specifications before ordering.

MC1608

Parts number	EHS	Nominal inductance [μ H]	Inductance tolerance	DC Resistance [m Ω]		Rated current(I _{dc1}) [A] (max.)	Rated current(I _{dc2}) [A] (max.)	Measuring frequency [MHz]	Thickness [mm] (max.)	Note
				(max.)	(typ.)					
MCKK1608TR47MVC	RoHS	0.47	$\pm 20\%$	65	54	2.60	3.00	1	1.00	

MC2012

Parts number	EHS	Nominal inductance [μ H]	Inductance tolerance	DC Resistance [m Ω]		Rated current(I _{dc1}) [A] (max.)	Rated current(I _{dc2}) [A] (max.)	Measuring frequency [MHz]	Thickness [mm] (max.)	Note
				(max.)	(typ.)					
MCKK2012T1R0MVC	RoHS	1.0	$\pm 20\%$	85	71	2.70	2.70	1	1.00	

※I_{dc1} is the DC value at which the initial L value is decreased within 30% by the application of DC bias. (at 20°C)

※I_{dc2} is the DC value at which the temperature of element is increased within 40°C by the application of DC bias. (at 20°C)

Derating of Rated Current

MC series

Derating of current is necessary for MC series depending on ambient temperature.
 Please refer to the chart shown below for appropriate derating of current.

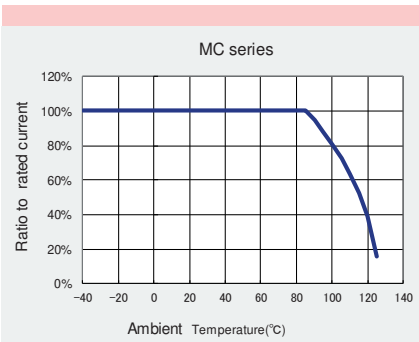

► This catalog contains the typical specification only due to the limitation of space. When you consider the purchase of our products, please check our product specification sheets. For details of each product (characteristics graph, reliability information, precautions for use, and so on), see our website (<http://www.ty-top.com/>).

Multilayer chip inductors

Multilayer chip inductors for high frequency, Multilayer chip bead inductors

Multilayer common mode choke coils (MC series F type)

Metal Multilayer Chip Power Inductors (MCOIL™ MC series)

PACKAGING

① Minimum Quantity

● Tape & Reel Packaging

Type	Thickness mm (inch)	Standard Quantity [pcs]	
		Paper Tape	Embossed Tape
CK 1608 (0603)	0.8 (0.031)	4000	—
CK 2125 (0805)	0.85 (0.033)	4000	—
	1.25 (0.049)	—	2000
CKS2125 (0805)	0.85 (0.033)	4000	—
	1.25 (0.049)	—	2000
CKP1608 (0603)	0.95 max (0.037 max)	4000	—
CKP2012 (0805)	1.0 max (0.039 max)	—	3000
CKP2016 (0806)	1.0 max (0.039 max)	—	3000
CKP2520 (1008)	0.8 max (0.031 max)	—	3000
	1.0 max (0.039 max)	—	3000
	1.2 max (0.047 max)	—	2000
LK 1005 (0402)	0.5 (0.020)	10000	—
LK 1608 (0603)	0.8 (0.031)	4000	—
LK 2125 (0805)	0.85 (0.033)	4000	—
	1.25 (0.049)	—	2000
HK 0603 (0201)	0.3 (0.012)	15000	—
HK 1005 (0402)	0.5 (0.020)	10000	—
HK 1608 (0603)	0.8 (0.031)	4000	—
HK 2125 (0805)	0.85 (0.033)	—	4000
	1.0 (0.039)	—	3000
HKQ0603S (0201)	0.3 (0.012)	15000	—
HKQ0603U (0201)	0.3 (0.012)	15000	—
AQ 105 (0402)	0.5 (0.020)	10000	—
BK 0603 (0201)	0.3 (0.012)	15000	—
BK 1005 (0402)	0.5 (0.020)	10000	—
BKH0603 (0201)	0.3 (0.012)	15000	—
BKH1005 (0402)	0.5 (0.020)	10000	—
BK 1608 (0603)	0.8 (0.031)	4000	—
BK 2125 (0805)	0.85 (0.033)	4000	—
	1.25 (0.049)	—	2000
BK 2010 (0804)	0.45 (0.018)	4000	—
BK 3216 (1206)	0.8 (0.031)	—	4000
BKP0603 (0201)	0.3 (0.012)	15000	—
BKP1005 (0402)	0.5 (0.020)	10000	—
BKP1608 (0603)	0.8 (0.031)	4000	—
BKP2125 (0805)	0.85 (0.033)	4000	—
MCF0605 (0202)	0.3 (0.012)	15000	—
MCF0806 (0302)	0.4 (0.016)	—	10000
MCF1210 (0504)	0.55 (0.022)	—	5000
MCF2010 (0804)	0.45 (0.018)	—	4000
MCEE1005 (0402)	0.55 max (0.022 max)	10000	—
MCEK1210 (0504)	0.5 max (0.020 max)	5000	—
MCFK1608 (0603)	0.6 max (0.024 max)	4000	—
MCFE1608 (0603)	0.65 max (0.026 max)	4000	—
MCHK1608 (0603)	0.8 max (0.031 max)	4000	—
MCKK1608 (0603)	1.0 max (0.039 max)	—	3000
MCHK2012 (0806)	0.8 max (0.031 max)	4000	—
MCKK2012 (0805)	1.0 max (0.039 max)	—	3000
MCFE2016 (0806)	0.65 max (0.026 max)	4000	—

► This catalog contains the typical specification only due to the limitation of space. When you consider the purchase of our products, please check our specification. For details of each product (characteristics graph, reliability information, precautions for use, and so on), see our Web site (<http://www.ty-top.com/>).

② Taping material

● Card board carrier tape

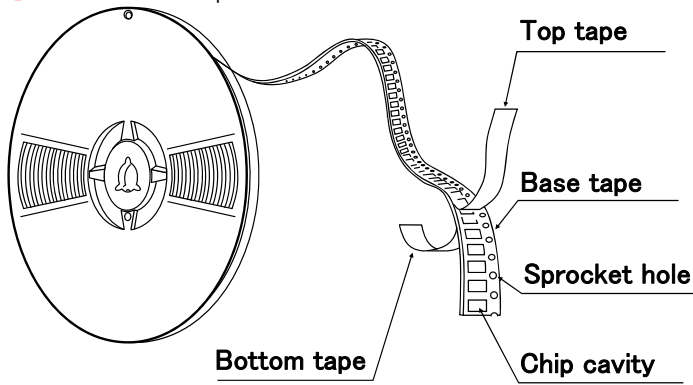

CK	1608
CKP	1608
CK	2125
CKS	2125
LK	1005
LK	1608
LK	2125
HK	0603
HK	1005
HK	1608
HKQ	0603
AQ	105

BK	0603
BK	1005
BK	1608
BK	2125
BK	2010
BKP	0603
BKP	1005
BKP	1608
BKP	2125
BKH	0603
BKH	1005
MCF	0605
MC	1005
MC	1210
MC	1608
MC	2012
MC	2016

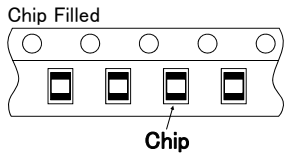

● Embossed Tape

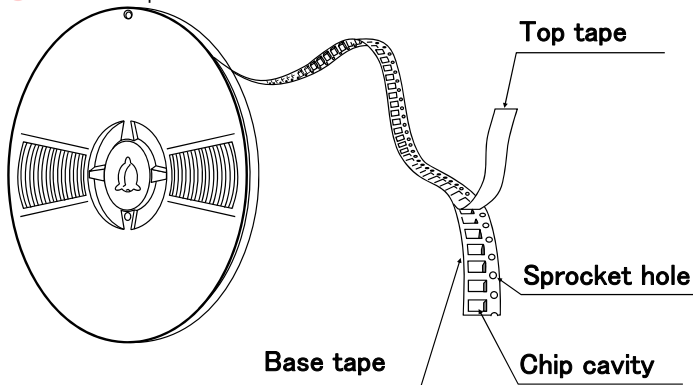

CK	2125
CKS	2125
CKP	2012
CKP	2016
CKP	2520
LK	2125
HK	2125

BK	2125
BK	3216
MCF	0806
MCF	1210
MCF	2010
MC	1608
MC	2012

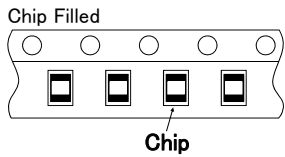

▶ This catalog contains the typical specification only due to the limitation of space. When you consider the purchase of our products, please check our specification. For details of each product (characteristics graph, reliability information, precautions for use, and so on), see our Web site (<http://www.ty-top.com/>).

③ Taping Dimensions

● Paper tape (8mm wide)

Unit: mm (inch)

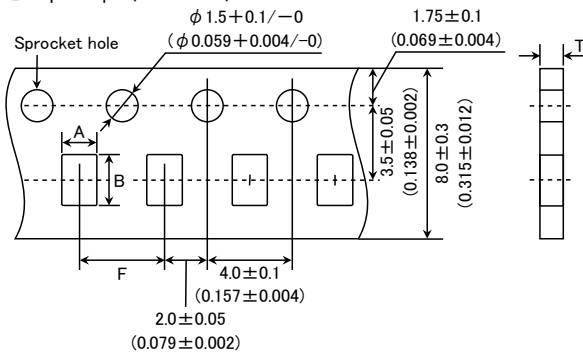

CK, CKS, CKP, LK, HK, HKQ, AQ, BK, BKP, BKH series

Type	Thickness	Chip cavity		Insertion Pitch	Tape Thickness
		A	B	F	T
HK 0603 (0201) HKQ0603S (0201) HKQ0603U (0201) BK 0603 (0201) BKH0603 (0201) BKP0603 (0201)	0.3 (0.012)	0.40 (0.016)	0.70 (0.028)	2.0±0.05 (0.079±0.002)	0.45max (0.018max)
LK 1005 (0402) HK 1005 (0402) BK 1005 (0402) BKH1005 (0402) BKP1005 (0402)	0.5 (0.020)	0.65 (0.026)	1.15 (0.045)	2.0±0.05 (0.079±0.002)	0.8max (0.031max)
CK 1608 (0603) LK 1608 (0603) HK 1608 (0603) BK 1608 (0603) BKP1608 (0603)	0.8 (0.031)	1.0 (0.039)	1.8 (0.071)	4.0±0.1 (0.157±0.004)	1.1max (0.043max)
CKP1608 (0603)	0.95 max (0.037max)				
BK 2010 (0804)	0.45 (0.018)	1.2 (0.047)	2.17 (0.085)	4.0±0.1 (0.157±0.004)	0.8max (0.031max)
CK 2125 (0805) CKS2125 (0805) LK 2125 (0805) BK 2125 (0805) BKP2125 (0805)	0.85 (0.033)	1.5 (0.059)	2.3 (0.091)	4.0±0.1 (0.157±0.004)	1.1max (0.043max)
AQ 105 (0402)	0.5 (0.020)	0.75 (0.030)	1.15 (0.045)	2.0±0.05 (0.079±0.002)	0.8max (0.031max)

Unit : mm (inch)

MC series F type

Type	Thickness	Chip cavity		Insertion Pitch	Tape Thickness
		A	B	F	T
MCF0605 (0202)	0.3 (0.012)	0.62 (0.024)	0.77 (0.030)	2.0±0.05 (0.079±0.002)	0.45max (0.018max)

Unit : mm (inch)

MCOIL™ MC series

Type	Thickness	Chip cavity		Insertion Pitch	Tape Thickness
		A	B	F	T
MCEE1005 (0402)	0.55 max (0.021 max)	0.8 (0.031)	1.3 (0.051)	2.0±0.05 (0.079±0.002)	0.64max (0.025max)
MCEK1210 (0504)	0.5 max (0.020 max)	1.3 (0.051)	1.55 (0.061)	4.0±0.1 (0.157±0.004)	0.64max (0.025max)
MCFK1608 (0603)	0.6 max (0.024 max)	1.1 (0.043)	1.9 (0.075)	4.0±0.1 (0.157±0.004)	0.72max (0.028max)
MCFE1608 (0603)	0.65 max (0.026 max)	1.1 (0.043)	1.9 (0.075)	4.0±0.1 (0.157±0.004)	0.72max (0.028max)
MCHK1608 (0603)	0.8 max (0.031 max)	1.2 (0.047)	2.0 (0.079)	4.0±0.1 (0.157±0.004)	0.9max (0.035max)
MCHK2012 (0805)	0.8 max (0.031 max)	1.65 (0.065)	2.4 (0.094)	4.0±0.1 (0.157±0.004)	0.9max (0.035max)
MCFE2016 (0806)	0.65 max (0.026 max)	1.95 (0.077)	2.3 (0.091)	4.0±0.1 (0.157±0.004)	0.72max (0.028max)

Unit : mm (inch)

▶ This catalog contains the typical specification only due to the limitation of space. When you consider the purchase of our products, please check our specification. For details of each product (characteristics graph, reliability information, precautions for use, and so on), see our Web site (<http://www.ty-top.com/>).

● Embossed Tape (8mm wide)

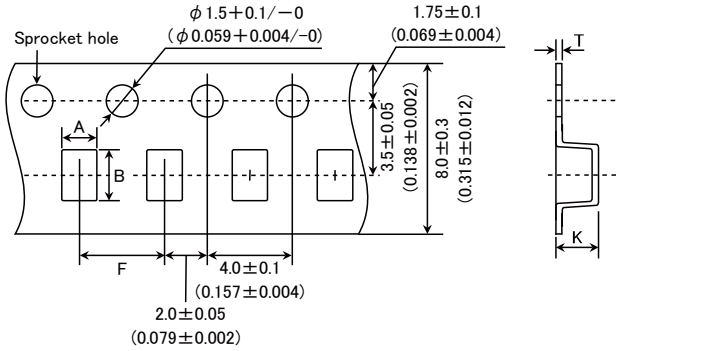

CK, CKS, CKP, LK, HK, BK series

Type	Thickness	Chip cavity		Insertion Pitch	Tape Thickness	
		A	B		K	T
HK 2125 (0805)	0.85 (0.033)	1.5 (0.059)	2.3 (0.091)	4.0±0.1 (0.157±0.004)	1.5max (0.059 max)	0.3max (0.012 max)
	1.0 (0.039)				2.0 max (0.079 max)	
CK 2125 (0805) CKS2125 (0805) LK 2125 (0805) BK 2125 (0805)	1.25 (0.049)				2.0 max (0.079 max)	
BK 3216 (1206)	0.8 (0.031)	1.9 (0.075)	3.5 (0.138)	4.0±0.1 (0.157±0.004)	1.4 max (0.055 max)	0.3 max (0.012 max)
CKP2012 (0805)	1.0 max (0.039 max)	1.55 (0.061)	2.3 (0.091)	4.0±0.1 (0.157±0.004)	1.3 max (0.051 max)	0.3 max (0.012 max)
CKP2016 (0806)	1.0 max (0.039 max)	1.8 (0.071)	2.2 (0.087)	4.0±0.1 (0.157±0.004)	1.3 max (0.051 max)	0.25 max (0.01 max)
CKP2520 (1008)	0.8 max (0.031 max)	2.3 (0.091)	2.8 (0.110)	4.0±0.1 (0.157±0.004)	1.4 max (0.055 max)	0.3 max (0.012 max)
	1.0 max (0.039 max)				1.4 max (0.055 max)	
	1.2 max (0.047 max)				1.7 max (0.067 max)	

單位 : mm (inch)

MC series F type

Type	Thickness	Chip cavity		Insertion Pitch	Tape Thickness	
		A	B		K	T
MCF0806 (0302)	0.4 (0.016)	0.75 (0.030)	0.95 (0.037)	2.0±0.05 (0.079±0.002)	0.55 max (0.022 max)	0.3 max (0.012 max)
MCF1210 (0504)	0.55 (0.022)	1.15 (0.045)	1.40 (0.055)	4.0±0.1 (0.157±0.004)	0.65 max (0.026 max)	0.3 max (0.012 max)
MCF2010 (0804)	0.45 (0.018)	1.1 (0.043)	2.3 (0.091)	4.0±0.1 (0.157±0.004)	0.85 max (0.033 max)	0.3 max (0.012 max)

Unit : mm (inch)

MCOIL™ MC series

Type	Thickness	Chip cavity		Insertion Pitch	Tape Thickness	
		A	B		K	T
MCKK1608 (0603)	1.0 max (0.039 max)	1.1 (0.043)	1.95 (0.077)	4.0±0.1 (0.157±0.004)	1.5 max (0.059 max)	0.3 max (0.012 max)
MCKK2012 (0805)	1.0 max (0.039 max)	1.55 (0.061)	2.35 (0.093)	4.0±0.1 (0.157±0.004)	1.45 max (0.057 max)	0.3 max (0.012 max)

Unit : mm (inch)

④ LEADER AND BLANK PORTION

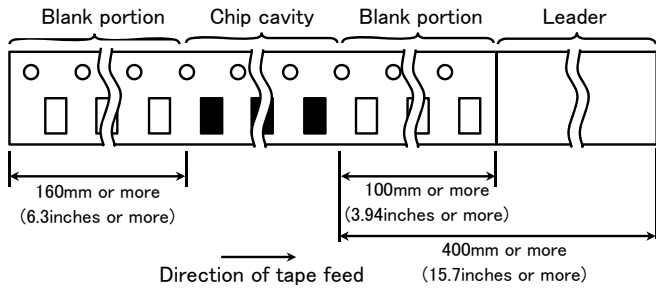

⑤ Reel Size

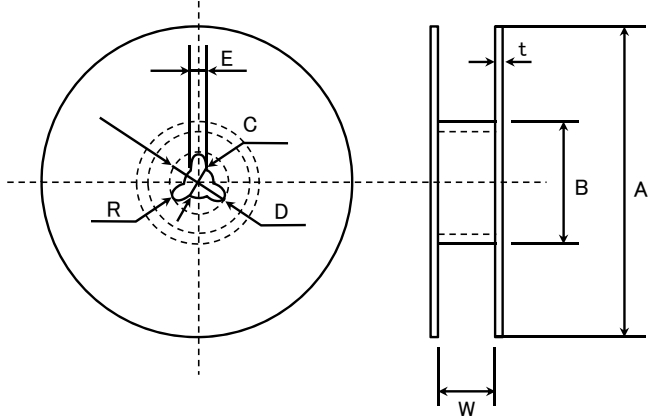

A	B	C	D	E	R
$\phi 178 \pm 2.0$	$\phi 60$ or more	$\phi 13.0 \pm 0.2$	$\phi 21.0 \pm 0.8$	2.0 ± 0.5	1.0

	t	W
4mm width tape	1.5max.	5 ± 1.0
8mm width tape	2.5max.	10 ± 1.5

(Unit : mm)

⑥ Top tape strength

The top tape requires a peel-off force of 0.1 to 0.7N (*) in the direction of the arrow as illustrated below. *) MCOIL™ MC series is 0.1 to 1.0N.

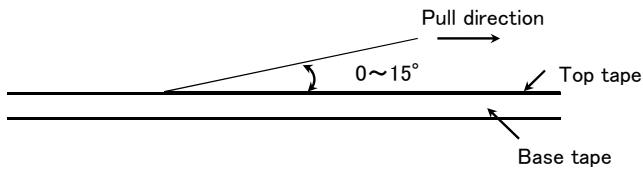

► This catalog contains the typical specification only due to the limitation of space. When you consider the purchase of our products, please check our specification. For details of each product (characteristics graph, reliability information, precautions for use, and so on), see our Web site (<http://www.ty-top.com/>).

Multilayer chip inductors

Multilayer chip inductors for high frequency, Multilayer chip bead inductors

Metal Multilayer Chip Power Inductors (MCOIL™ MC series)

RELIABILITY DATA

1. Operating Temperature Range		
Specified Value	BK series	-55 ~ +125°C
	BKP series	-55 ~ +125°C (BKP0603: Including self-generated heat)
	LK series	-40 ~ +85°C
	HK series	-55 ~ +125°C
	MCOIL™ MC series	-40 ~ +125°C (Including self-generated heat)

2. Storage Temperature Range		
Specified Value	BK series	-55 ~ +125°C
	BKP series	-55 ~ +125°C (BKP0603: -55 ~ +85°C)
	LK series	-40 ~ +85°C
	HK series	-55 ~ +125°C
	MCOIL™ MC series	-40 ~ +85°C

3. Rated Current		
Specified Value	BK series	The temperature of the element is increased within 20°C.
	BKP series	The temperature of the element is increased within 40°C
	LK series	The decreasing-rate of inductance value is within 5 %
	HK series	The decreasing-rate of inductance value is within 5 %, or the temperature of the element is increased within 20°C
	MCOIL™ MC series	Idc1: The decreasing-rate of inductance value is within 30 % Idc2: The temperature of the element is increased within 40°C

4. Impedance		
Specified Value	BK series	Refer to each specification.
	BKP series	
Test Methods and Remarks	Measuring frequency : 100 ± 1MHz Measuring equipment : 4291A (or its equivalent) Measuring jig : 16192A (or its equivalent), HW:16193A (or its equivalent)	

5. Inductance		
Specified Value	LK series	Refer to each specification.
	HK series	
	MCOIL™ MC series	
Test Methods and Remarks	LK Series Measuring frequency : 10 ~ 25MHz Measuring equipment /jig : 4291A + 16193A (or its equivalent) Measuring current : 1mA rms	
	HK Series Measuring frequency : 100MHz Measuring equipment /jig : 4291A + 16193A (or its equivalent)	
	MCOIL™ MC Series Measuring frequency : 1MHz Measuring equipment : E4991+16197A (or its equivalent)	

6. Q		
Specified Value	LK series	Refer to each specification.
	HK series	
Test Methods and Remarks	LK Series Measuring frequency : Refer to each specification. Measuring equipment /jig : 4291A + 16193A (or its equivalent) Measuring current : 1mA rms	
	HK Series Measuring frequency : 100MHz Measuring equipment /jig : 4291A + 16193A (or its equivalent)	

▶ This catalog contains the typical specification only due to the limitation of space. When you consider the purchase of our products, please check our specification. For details of each product (characteristics graph, reliability information, precautions for use, and so on), see our Web site (<http://www.ty-top.com/>).

7. DC Resistance		
Specified Value	BK series	Refer to each specification.
	BKP series	
	LK series	
	HK series	
	MCOIL™ MC series	
Test Methods and Remarks	Measuring equipment: IWATSU VOAC7512(or its equivalent)	

8. Self Resonance Frequency (SRF)		
Specified Value	LK series	Refer to each specification.
	HK series	
Test Methods and Remarks	LK Series Measuring equipment : 4291A (or its equivalent) Measuring jig : 16193A (or its equivalent)	
	HK Series Measuring equipment : 8719C (or its equivalent)	

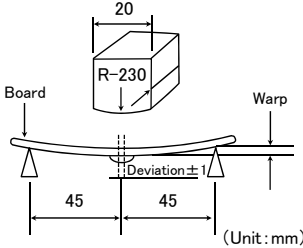
9. Resistance to Flexure of Substrate		
Specified Value	BK series	No mechanical damage.
	BKP series	
	LK series	
	HK series	
	MCOIL™ MC series	
Test Methods and Remarks	Warp : 2mm Testing board : glass epoxy-resin substrate Thickness : 0.8mm	
	 <p>(Unit: mm)</p>	

10. Solderability		
Specified Value	BK series	At least 90% of terminal electrode is covered by new solder.
	BKP series	
	LK series	
	HK series	
	MCOIL™ MC series	
Test Methods and Remarks	Solder temperature : 230±5°C (JIS Z 3282 H60A or H63A) Solder temperature : 245±3°C (Sn/3.0Ag/0.5Cu) Duration : 4±1 sec.	

11. Resistance to Soldering		
Specified Value	BK series	Appearance: No significant abnormality
	BKP series	Impedance change: Within ±30%
	LK series	Appearance: No significant abnormality Inductance change: Within ±15%
	HK series	Appearance: No significant abnormality Inductance change: Within ±5%
	MCOIL™ MC series	Appearance: No significant abnormality Inductance change: Within ±10%
Test Methods and Remarks	Solder temperature : 260±5°C Duration : 10±0.5 sec. Preheating temperature : 150 to 180°C Preheating time : 3 min. Flux : Immersion into methanol solution with colophony for 3 to 5 sec. Recovery : 2 to 3 hrs of recovery under the standard condition after the test. (See Note 1)	

12. Thermal Shock																	
Specified Value	BK series	Appearance : No significant abnormality															
	BKP series	Impedance change : Within $\pm 30\%$															
	LK series	Appearance : No significant abnormality Inductance change : Within $\pm 10\%$ Q change : Within $\pm 30\%$															
	HK series	Appearance : No significant abnormality Inductance change : Within $\pm 10\%$ Q change : Within $\pm 20\%$															
	MCOIL™ MC series	Appearance : No significant abnormality Inductance change : Within $\pm 10\%$															
Test Methods and Remarks	BK, HK, BKP Series Conditions for 1 cycle																
	<table border="1"> <thead> <tr> <th>Step</th> <th>temperature (°C)</th> <th>time (min.)</th> </tr> </thead> <tbody> <tr> <td>1</td> <td>-55°C +0/-3</td> <td>30±3</td> </tr> <tr> <td>2</td> <td>Room temperature</td> <td>2~3</td> </tr> <tr> <td>3</td> <td>+125°C(BKP0603: +85°C) +3/-0</td> <td>30±3</td> </tr> <tr> <td>4</td> <td>Room temperature</td> <td>2~3</td> </tr> </tbody> </table>	Step	temperature (°C)	time (min.)	1	-55°C +0/-3	30±3	2	Room temperature	2~3	3	+125°C(BKP0603: +85°C) +3/-0	30±3	4	Room temperature	2~3	
	Step	temperature (°C)	time (min.)														
	1	-55°C +0/-3	30±3														
	2	Room temperature	2~3														
	3	+125°C(BKP0603: +85°C) +3/-0	30±3														
	4	Room temperature	2~3														
	Number of cycles : 100																
	LK Series Conditions for 1 cycle																
	<table border="1"> <thead> <tr> <th>Step</th> <th>temperature (°C)</th> <th>time (min.)</th> </tr> </thead> <tbody> <tr> <td>1</td> <td>-40°C +0/-3</td> <td>30±3</td> </tr> <tr> <td>2</td> <td>Room temperature</td> <td>2~3</td> </tr> <tr> <td>3</td> <td>+85°C +3/-0</td> <td>30±3</td> </tr> <tr> <td>4</td> <td>Room temperature</td> <td>2~3</td> </tr> </tbody> </table>	Step	temperature (°C)	time (min.)	1	-40°C +0/-3	30±3	2	Room temperature	2~3	3	+85°C +3/-0	30±3	4	Room temperature	2~3	
Step	temperature (°C)	time (min.)															
1	-40°C +0/-3	30±3															
2	Room temperature	2~3															
3	+85°C +3/-0	30±3															
4	Room temperature	2~3															
Number of cycles : 100																	
MCOIL™ MC series Conditions for 1 cycle																	
<table border="1"> <thead> <tr> <th>Step</th> <th>temperature (°C)</th> <th>time (min.)</th> </tr> </thead> <tbody> <tr> <td>1</td> <td>-40°C +0/-3</td> <td>30±3</td> </tr> <tr> <td>2</td> <td>Room temperature</td> <td>2~3</td> </tr> <tr> <td>3</td> <td>+85°C +3/-0</td> <td>30±3</td> </tr> <tr> <td>4</td> <td>Room temperature</td> <td>2~3</td> </tr> </tbody> </table>	Step	temperature (°C)	time (min.)	1	-40°C +0/-3	30±3	2	Room temperature	2~3	3	+85°C +3/-0	30±3	4	Room temperature	2~3		
Step	temperature (°C)	time (min.)															
1	-40°C +0/-3	30±3															
2	Room temperature	2~3															
3	+85°C +3/-0	30±3															
4	Room temperature	2~3															
Number of cycles : 1000																	
Recovery : 2 to 3 hrs of recovery under the standard condition after the test. (See Note 1)																	

13. Damp Heat (Steady state)		
Specified Value	BK series	Appearance : No significant abnormality
	BKP series	Impedance change : Within $\pm 30\%$
	LK series	Appearance : No significant abnormality Inductance change : Within $\pm 10\%$ Q change : Within $\pm 30\%$
	HK series	Appearance : No significant abnormality Inductance change : Within $\pm 10\%$ Q change : Within $\pm 20\%$
	MCOIL™ MC series	Appearance : No significant abnormality Inductance change : Within $\pm 10\%$
Test Methods and Remarks	BK, BKP, LK series Temperature : 40±2°C Humidity : 90 to 95%RH Duration : 1000+24/-0 hrs Recovery : 2 to 3 hrs of recovery under the standard condition after the removal from test chamber. (See Note 1)	
	HK, MCOIL™ MC series Temperature : 60±2°C Humidity : 90 to 95%RH Duration : 1000+24/-0 hrs Recovery : 2 to 3 hrs of recovery under the standard condition after the removal from test chamber. (See Note 1)	

14. Loading under Damp Heat		
Specified Value	BK series	Appearance : No significant abnormality
	BKP series	Impedance change : Within $\pm 30\%$
	LK series	Appearance : No significant abnormality Inductance change : Within $\pm 10\%$ Q change : Within $\pm 30\%$
	HK series	Appearance : No significant abnormality Inductance change : Within $\pm 10\%$ Q change : Within $\pm 20\%$
	MCOIL™ MC series	Appearance : No significant abnormality Inductance change : Within $\pm 10\%$
Test Methods and Remarks	BK, BKP, LK series Temperature : $40 \pm 2^\circ\text{C}$ Humidity : 90 to 95%RH Applied current : Rated current Duration : $1000 + 24 / - 0$ hrs Recovery : 2 to 3 hrs of recovery under the standard condition after the removal from test chamber. (See Note 1)	
	HK, MCOIL™ MC series Temperature : $60 \pm 2^\circ\text{C}$ Humidity : 90 to 95%RH Applied current : Rated current Duration : $1000 + 24 / - 0$ hrs Recovery : 2 to 3 hrs of recovery under the standard condition after the removal from test chamber. (See Note 1)	

15. Loading at High Temperature		
Specified Value	BK series	Appearance : No significant abnormality
	BKP series	Impedance change : Within $\pm 30\%$
	LK series	Appearance : No significant abnormality Inductance change : Within $\pm 10\%$ Q change : Within $\pm 30\%$
	HK series	Appearance : No significant abnormality Inductance change : Within $\pm 10\%$ Q change : Within $\pm 20\%$
	MCOIL™ MC series	Appearance : No significant abnormality Inductance change : Within $\pm 10\%$
Test Methods and Remarks	BK, BKP (except 0603) *, HK* series Temperature : $125 \pm 2^\circ\text{C}$ Applied current : Rated current (* BKP series and HK series apply the rated current of 125°C) Duration : $1000 + 24 / - 0$ hrs Recovery : 2 to 3 hrs of recovery under the standard condition after the removal from test chamber. (See Note 1)	
	BKP0603, LK, MCOIL™ MC ** series Temperature : $85 \pm 2^\circ\text{C}$ Applied current : Rated current (** MCOIL™ MC series : I_{dc2max}) Duration : $1000 + 24 / - 0$ 時間 Recovery : 2 to 3 hrs of recovery under the standard condition after the removal from test chamber. (See Note 1)	

(Note 1) Measurement shall be made after 48 ± 2 hrs of recovery under the standard condition.

Note on standard condition: "standard condition" referred to herein is defined as follows:

5 to 35°C of temperature, 25 to 85% relative humidity.

When there are questions concerning measurement results:

In order to provide correlation data, the test shall be conducted under condition of $20 \pm 2^\circ\text{C}$ of temperature, 60 to 70% relative humidity, and 86 to 106kPa of air pressure. Unless otherwise specified, all the tests are conducted under the "standard condition."

Metal Multilayer Chip Power Inductors (MCOIL™ MC series)

PRECAUTIONS

1. Circuit Design

Precautions

- ◆ Verification of operating environment, electrical rating and performance
 1. A malfunction in medical equipment, spacecraft, nuclear reactors, etc. may cause serious harm to human life or have severe social ramifications. As such, any inductors to be used in such equipment may require higher safety and/or reliability considerations and should be clearly differentiated from components used in general purpose applications.
 2. When inductors are used in places where dew condensation develops and/or where corrosive gas such as hydrogen sulfide, sulfurous acid, or chlorine exists in the air, characteristic deterioration may occur. Please do not use inductors under such environmental conditions.
- ◆ Operating Current (Verification of Rated current)
 1. The operating current including inrush current for inductors must always be lower than their rated values.
 2. Do not apply current in excess of the rated value because the inductance may be reduced due to the magnetic saturation effect.
- ◆ Temperature rise

Temperature rise of power choke coil depends on the installation condition in end products.
Make sure that temperature rise of power choke coils in actual end products is within the specified temperature range.

2. PCB Design

Precautions

- ◆ Pattern configurations (Design of Land-patterns)

When inductors are mounted on a PCB, the size of land patterns and the amount of solder used (size of fillet) can directly affect inductor performance. Therefore, the following items must be carefully considered in the design of solder land patterns:

 - (1) The amount of solder applied can affect the ability of chips to withstand mechanical stresses which may lead to breaking or cracking. Therefore, when designing land-patterns it is necessary to consider the appropriate size and configuration of the solder pads which in turn determines the amount of solder necessary to form the fillets.
 - (2) When more than one part is jointly soldered onto the same land or pad, the pad must be designed so that each component's soldering point is separated by solder-resist.
- ◆ Pattern configurations (Inductor layout on panelized [breakaway] PC boards)

After inductors have been mounted on the boards, chips can be subjected to mechanical stresses in subsequent manufacturing processes (PCB cutting, board inspection, mounting of additional parts, assembly into the chassis, wave soldering the reflow soldered boards etc.) For this reason, planning pattern configurations and the position of SMD inductors should be carefully performed to minimize stress.

Technical considerations

- ◆ Pattern configurations (Design of Land-patterns)

The following diagrams and tables show some examples of recommended patterns to prevent excessive solder amounts. Examples of improper pattern designs are also shown.

- (1) Recommended land dimensions for a typical chip inductor land patterns for PCBs
(Unit: mm)

Type	1608	2012
A	0.7	0.95
B	0.9	0.8
C	1.0	1.4

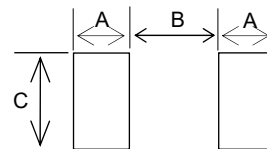

- (2) Examples of good and bad solder application

Item	Not recommended	Recommended
Mixed mounting of SMD and leaded components	Lead wire of component	Solder-resist
Component placement close to the chassis	Chassis Solder (for grounding) Electrode pattern	Solder-resist
Hand-soldering of leaded components near mounted components	Lead wire of component Soldering iron	Solder-resist
Horizontal component placement	Solder-resist	Solder-resist

▶ This catalog contains the typical specification only due to the limitation of space. When you consider the purchase of our products, please check our specification.
For details of each product (characteristics graph, reliability information, precautions for use, and so on), see our Web site (<http://www.ty-top.com/>).

◆Pattern configurations (Inductor layout on panelized [breakaway] PC boards)

1. The following are examples of good and bad inductor layout; SMD inductors should be located to minimize any possible mechanical stresses from board warp or deflection.

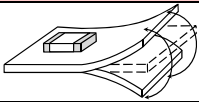
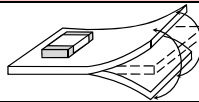
Item	Not recommended	Recommended
Deflection of the board		 Position the component at a right angle to the direction of the mechanical stresses that are anticipated.

2. To layout the inductors for the breakaway PC board, it should be noted that the amount of mechanical stresses given will vary depending on inductor layout.

An example below should be counted for better design.

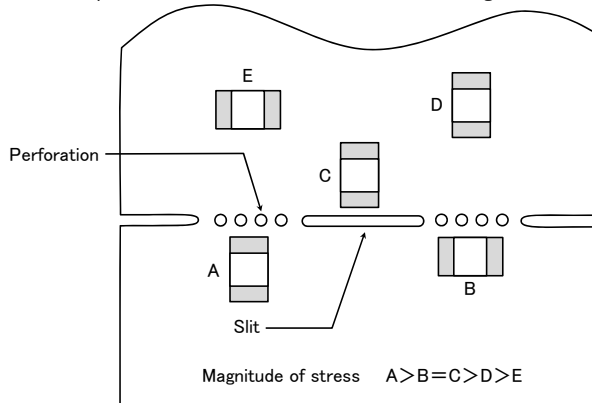

3. When breaking PC boards along their perforations, the amount of mechanical stress on the inductors can vary according to the method used. The following methods are listed in order from least stressful to most stressful: push-back, slit, V-grooving, and perforation. Thus, any ideal SMD inductor layout must also consider the PCB splitting procedure.

3. Considerations for automatic placement

Precautions

◆Adjustment of mounting machine

- Excessive impact load should not be imposed on the inductors when mounting onto the PC boards.
- The maintenance and inspection of the moulder should be conducted periodically.

Technical considerations

◆Adjustment of mounting machine

- If the lower limit of the pick-up nozzle is low, too much force may be imposed on the inductors, causing damage. To avoid this, the following points should be considered before lowering the pick-up nozzle:
 - The lower limit of the pick-up nozzle should be adjusted to the surface level of the PC board after correcting for deflection of the board.
 - The pick-up pressure should be adjusted between 1 and 3N static loads.
 - To reduce the amount of deflection of the board caused by impact of the pick-up nozzle, supporting pins or back-up pins should be used under the PC board. The following diagrams show some typical examples of good pick-up nozzle placement:

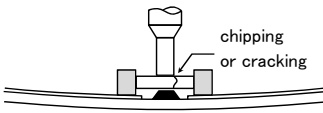
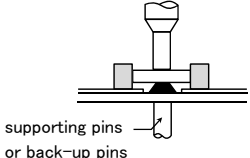
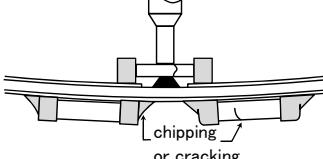
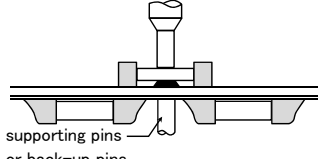
Item	Improper method	Proper method
Single-sided mounting	 chipping or cracking	 supporting pins or back-up pins
Double-sided mounting	 chipping or cracking	 supporting pins or back-up pins

- As the alignment pin wears out, adjustment of the nozzle height can cause chipping or cracking of the inductors because of mechanical impact on the inductors. To avoid this, the monitoring of the width between the alignment pin in the stopped position, and maintenance, inspection and replacement of the pin should be conducted periodically.

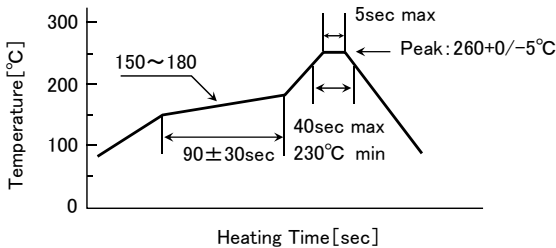
4. Soldering	
Precautions	<ul style="list-style-type: none"> ◆Reflow soldering <ul style="list-style-type: none"> • Please contact any of our offices for a reflow soldering, and refer to the recommended condition specified. • The product shall be used reflow soldering only. • Please do not add any stress to a product until it returns in normal temperature after reflow soldering. ◆Lead free soldering <ul style="list-style-type: none"> • When using products with lead free soldering, we request to use them after confirming adhesion, temperature of resistance to soldering heat, soldering etc sufficiently. ◆The conditions for Reworking with soldering irons <ul style="list-style-type: none"> • Put the soldering iron on the land-pattern and don't touch it to the inductor directly. <p>Soldering iron's temperature below 350 degC , Duration 3 seconds or less</p>
Technical considerations	<ul style="list-style-type: none"> ◆Reflow soldering <ul style="list-style-type: none"> • If products are used beyond the range of the recommended conditions, heat stresses may deform the products, and consequently degrade the reliability of the products. <p>Recommended reflow condition (Pb free solder)</p>  <p>The allowable number of reflow soldering is 3 times.</p>

5. Cleaning	
Precautions	<ul style="list-style-type: none"> ◆Cleaning conditions <ul style="list-style-type: none"> • Washing by supersonic waves shall be avoided.
Technical considerations	<ul style="list-style-type: none"> ◆Cleaning conditions <ul style="list-style-type: none"> • If washed by supersonic waves, the products might be broken.

6. Resin coating and mold	
Precautions	<ol style="list-style-type: none"> 1. With some type of resins a decomposition gas or chemical reaction vapor may remain inside the resin during the hardening period or while left under normal storage conditions resulting in the deterioration of the inductor's performance. 2. Thermal expansion and thermal shrinkage characteristics of resins may lead to the deterioration of inductors' performance. 3. When a resin hardening temperature is higher than inductor operating temperature, the stresses generated by the excessive heat may lead to damage in inductors. 4. In prior to use, please make the reliability evaluation with the product mounted in your application set.

7. Handling	
Precautions	<ul style="list-style-type: none"> ◆Breakaway PC boards (splitting along perforations) <ol style="list-style-type: none"> 1. When splitting the PC board after mounting inductors and other components, care is required so as not to give any stresses of deflection or twisting to the board. 2. Board separation should not be done manually, but by using the appropriate devices. ◆General handling precautions <ul style="list-style-type: none"> • Always wear static control bands to protect against ESD. • Keep the inductors away from all magnets and magnetic objects. • Use non-magnetic tweezers when handling inductors. • Any devices used with the inductors (soldering irons, measuring instruments) should be properly grounded. • Keep bare hands and metal products (i.e., metal desk) away from inductor electrodes or conductive areas that lead to chip electrodes. • Keep inductors away from items that generate magnetic fields such as speakers or coils. ◆Mechanical considerations <ul style="list-style-type: none"> Be careful not to subject the inductors to excessive mechanical shocks. (1) If inductors are dropped on the floor or a hard surface they should not be used. (2) When handling the mounted boards, be careful that the mounted components do not come in contact with or bump against other boards or components.

▶ This catalog contains the typical specification only due to the limitation of space. When you consider the purchase of our products, please check our specification. For details of each product (characteristics graph, reliability information, precautions for use, and so on), see our Web site (<http://www.ty-top.com/>).

8. Storage conditions

Precautions	<p>◆Storage To maintain the solderability of terminal electrodes and to keep the packaging material in good condition, care must be taken to control temperature and humidity in the storage area. Humidity should especially be kept as low as possible.</p> <ul style="list-style-type: none">•Recommended conditions Ambient temperature: 30°C or below Humidity: 70% RH or below <p>The ambient temperature must be kept below 40°C. Even under ideal storage conditions, solderability of inductor is deteriorated as time passes, so inductors should be used within 6 months from the time of delivery.</p> <ul style="list-style-type: none">•Inductor should be kept where no chlorine or sulfur exists in the air.
Technical considerations	<p>◆Storage If the parts are stocked in a high temperature and humidity environment, problems such as reduced solderability caused by oxidation of terminal electrodes and deterioration of taping/package materials may take place. For this reason, components should be used within 6 months from the time of delivery. If exceeding the above period, please check solderability before using the inductors.</p>

METAL CORE SMD POWER INDUCTORS (MCOIL™ MD SERIES)

AEC-Q200 Grade 3 (we conduct the evaluation at the test condition of Grade 3.)

*Operating environment Temp:-40~85°C

REFLOW

AEC-Q200

■ PART NUMBER

*Operating Temp. : -40~125°C (Including self-generated heat)



Δ=Blank space

① Series name

Code	Series name
MD	Metal base coil specification

② Dimensions (H)

Code	Dimensions (H) [mm]
KK	1.0
MK	1.2
WK	2.0

③ Dimensions (L × W)

Code	Dimensions (L × W) [mm]
2020	2.0 × 2.0
3030	3.0 × 3.0
4040	4.0 × 4.0

④ Packaging

Code	Packaging
T	Taping

⑤ Nominal inductance

Code (example)	Nominal inductance [μH]
R47	0.47
1R0	1.0
4R7	4.7

※R=Decimal point

⑥ Inductance tolerance

Code	Inductance tolerance
M	±20%
N	±30%

⑦ Special code 1

Code	Special code
F	Ferrite coating
M	Metal coating

⑧ Special code 2

Code	Special code
ΔΔ	Standard

⑨ Internal code

Code	Internal code
V	Inductor for Automotive
8	Inductor for Telecommunications infrastructure and Industrial equipment / Medical devices

■ STANDARD EXTERNAL DIMENSIONS

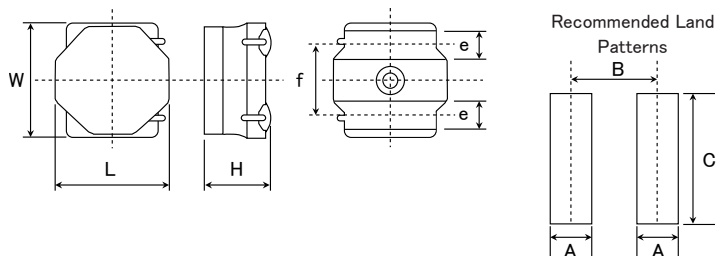

Type	A	B	C
MDKK2020	0.65	1.35	2.0
MDMK2020			
MDKK3030	0.8	2.2	2.7
MDMK3030			
MDMK4040/ MDWK4040	1.2	2.8	3.7

Unit: mm

Type	L	W	H	e	f	Standard quantity [pcs] Taping
MDKK2020	2.0±0.15 (0.079±0.006)	2.0±0.15 (0.079±0.006)	1.0 max (0.039 max)	0.50±0.2 (0.02±0.008)	1.25±0.2 (0.049±0.008)	2500
MDMK2020	2.0±0.15 (0.079±0.006)	2.0±0.15 (0.079±0.006)	1.2 max (0.047 max)	0.50±0.2 (0.02±0.008)	1.25±0.2 (0.049±0.008)	2500
MDKK3030	3.0±0.1 (0.118±0.004)	3.0±0.1 (0.118±0.004)	1.0 max (0.039 max)	0.90±0.2 (0.035±0.008)	1.9±0.2 (0.075±0.008)	2000
MDMK3030	3.0±0.1 (0.118±0.004)	3.0±0.1 (0.118±0.004)	1.2 max (0.047 max)	0.90±0.2 (0.035±0.008)	1.9±0.2 (0.075±0.008)	2000
MDMK4040	4.0±0.2 (0.157±0.008)	4.0±0.2 (0.157±0.008)	1.2 max (0.047 max)	1.1±0.2 (0.043±0.008)	2.5±0.2 (0.098±0.008)	1000
MDWK4040	4.0±0.2 (0.157±0.008)	4.0±0.2 (0.157±0.008)	2.0 max (0.079 max)	1.1±0.2 (0.043±0.008)	2.5±0.2 (0.098±0.008)	700

Unit: mm (inch)

► This catalog contains the typical specification only due to the limitation of space. When you consider the purchase of our products, please check our product specification sheets. For details of each product (characteristics graph, reliability information, precautions for use, and so on), see our website (<http://www.ty-top.com/>).

PART NUMBER

• All the Metal Core SMD Power Inductors of the catalog lineup are RoHS compliant.

Notes)

- The exchange of individual specifications is necessary depending on your application and/or circuit condition. Please contact TAIYO YUDEN's official sales channel.
- For Automotive (AEC-Q200 Qualified) products for BODY & CHASSIS, and INFOTAINMENT. Please check "Automotive Application Guide" for further details before using the products.
 - < **AEC-Q200** : AEC-Q200 qualified >
- All the Metal Core SMD Power Inductors for Automotive products are tested based on the test conditions and methods defined in AEC-Q200 by family item.
- Please consult with TAIYO YUDEN's official sales channel for the details of the product specifications and AEC-Q200 test results, etc., and please review and approve the product specifications before ordering.

MDKK2020 type 【Thickness: 1.0mm max】

Part number	Nominal inductance [μH]	Inductance tolerance	DC Resistance [Ω] (max.)	Rated current ※) [mA]		Measuring frequency [MHz]	Note
				Saturation current Idc1 Max (Typ)	Temperature rise current Idc2 Max (Typ)		
MDKK2020TR47MM V	0.47	±20%	0.046	3,500 (4,150)	2,200 (2,500)	1	
MDKK2020TR68MM V	0.68	±20%	0.060	3,200 (3,650)	2,000 (2,100)	1	
MDKK2020T1R0MM V	1	±20%	0.085	2,900 (3,400)	1,700 (1,900)	1	
MDKK2020T1R5MM V	1.5	±20%	0.133	1,900 (2,250)	1,350 (1,500)	1	
MDKK2020T2R2MM V	2.2	±20%	0.165	1,650 (1,950)	1,200 (1,350)	1	
MDKK2020T3R3MM V	3.3	±20%	0.275	1,300 (1,550)	940 (1,050)	1	
MDKK2020T4R7MM V	4.7	±20%	0.435	1,050 (1,250)	750 (850)	1	
MDKK2020T100MM V	10	±20%	0.690	750 (900)	630 (680)	1	

Absolute maximum voltage: DC20V

(Typ): Reference

MDMK2020 type 【Thickness: 1.2mm max】

Part number	Nominal inductance [μH]	Inductance tolerance	DC Resistance [Ω] (max.)	Rated current ※) [mA]		Measuring frequency [MHz]	Note
				Saturation current Idc1 Max (Typ)	Temperature rise current Idc2 Max (Typ)		
MDMK2020TR47MM V	0.47	±20%	0.046	4,200 (4,800)	2,300 (2,450)	1	
MDMK2020TR68MM V	0.68	±20%	0.058	3,500 (4,100)	2,000 (2,200)	1	
MDMK2020T1R0MM V	1	±20%	0.064	2,550 (2,900)	1,900 (2,050)	1	
MDMK2020T1R5MM V	1.5	±20%	0.086	2,000 (2,300)	1,650 (1,750)	1	
MDMK2020T2R2MM V	2.2	±20%	0.109	1,750 (2,000)	1,450 (1,550)	1	
MDMK2020T3R3MM V	3.3	±20%	0.178	1,350 (1,550)	1,150 (1,200)	1	
MDMK2020T4R7MM V	4.7	±20%	0.242	1,150 (1,300)	950 (1,050)	1	

Absolute maximum voltage: DC20V

(Typ): Reference

MDKK3030 type 【Thickness: 1.0mm max】

Part number	Nominal inductance [μH]	Inductance tolerance	DC Resistance [Ω] (max.)	Rated current ※) [mA]		Measuring frequency [MHz]	Note
				Saturation current Idc1 Max (Typ)	Temperature rise current Idc2 Max (Typ)		
MDKK3030TR47MM V	0.47	±20%	0.039	5,400 (6,500)	3,900 (4,500)	1	
MDKK3030T1R0MM V	1.0	±20%	0.086	4,400 (5,200)	2,400 (2,800)	1	
MDKK3030T1R5MM V	1.5	±20%	0.100	3,000 (3,500)	2,100 (2,400)	1	
MDKK3030T2R2MM V	2.2	±20%	0.144	2,500 (3,000)	1,900 (2,200)	1	
MDKK3030T3R3MM V	3.3	±20%	0.248	2,000 (2,400)	1,350 (1,500)	1	
MDKK3030T4R7MM V	4.7	±20%	0.345	1,700 (2,000)	1,150 (1,300)	1	
MDKK3030T6R8MM V	6.8	±20%	0.437	1,400 (1,700)	1,000 (1,150)	1	
MDKK3030T100MM V	10	±20%	0.575	1,100 (1,300)	850 (1,000)	1	

Absolute maximum voltage: DC20V

(Typ): Reference

MDMK3030 type 【Thickness: 1.2mm max】

Part number	Nominal inductance [μH]	Inductance tolerance	DC Resistance [Ω] (max.)	Rated current ※) [mA]		Measuring frequency [MHz]	Note
				Saturation current Idc1 Max (Typ)	Temperature rise current Idc2 Max (Typ)		
MDMK3030TR30MM V	0.30	±20%	0.020	7,600 (9,200)	5,500 (6,400)	1	
MDMK3030TR33MM V	0.33	±20%	0.020	6,400 (8,700)	5,500 (6,400)	1	
MDMK3030TR47MM V	0.47	±20%	0.027	6,300 (7,500)	4,700 (5,500)	1	
MDMK3030T1R0MM V	1.0	±20%	0.050	4,300 (5,100)	3,300 (3,900)	1	
MDMK3030T1R5MM V	1.5	±20%	0.074	3,400 (4,100)	2,500 (3,000)	1	
MDMK3030T2R2MM V	2.2	±20%	0.112	2,800 (3,600)	2,100 (2,400)	1	
MDMK3030T3R3MM V	3.3	±20%	0.173	2,100 (2,700)	1,650 (1,900)	1	
MDMK3030T4R7MM V	4.7	±20%	0.263	1,800 (2,300)	1,350 (1,550)	1	

Absolute maximum voltage: DC20V

(Typ): Reference

※) The saturation current value (Idc1) is the DC current value having inductance decrease down to 30%. (at 20°C)

※1-1) The temperature rise current value (Idc2) is the DC current value having temperature increase by 40°C, when mounted in FR4 High heat dissipation board (board thickness: 1.0mm copper thickness: 0.035mm, board size: 110 × 30 × 1.0mm, land size: 12.6 × 19.6mm). (at 20°C)

※1-2) The temperature rise current value (Idc2) is the DC current value having temperature increase by 40°C, when mounted in FR4 High heat dissipation board (board thickness: 1.6mm copper thickness: 0.050mm, board size: 100 × 100 × 1.6mm, land size: 14.6 × 43mm). (at 20°C)

※1-3) The temperature rise current value (Idc2) is the DC current value having temperature increase by 40°C, when mounted in FR4 High heat dissipation board (board thickness: 1.6mm copper thickness: 0.050mm, board size: 100 × 100 × 1.6mm, land size: 44.5 × 90mm). (at 20°C)

※) The rated current is the DC current value that satisfies both of current value saturation current value and temperature rise current value.

※1-1) MDKK2020, MDMK2020 type

※1-2) MDKK3030, MDMK3030 type

※1-3) MDMK4040, MDWK4040 type

▶ This catalog contains the typical specification only due to the limitation of space. When you consider the purchase of our products, please check our product specification sheets. For details of each product (characteristics graph, reliability information, precautions for use, and so on), see our website (<http://www.ty-top.com/>).

■ PART NUMBER

● MDMK4040F type [Thickness: 1.2mm max]

Part number	Nominal inductance [μH]	Inductance tolerance	DC Resistance [Ω] (max.)	Rated current ※) [mA]		Measuring frequency [kHz]	Note
				Saturation current Idc1 Max (Typ)	Temperature rise current Idc2 Max (Typ)		
MDMK4040TR47MF V	0.47	±20%	0.029	7,500 (10,000)	4,600 (5,400)	100	
MDMK4040T1R0MF V	1.0	±20%	0.047	5,200 (7,500)	3,500 (4,200)	100	
MDMK4040T1R2MF V	1.2	±20%	0.047	4,200 (6,200)	3,500 (4,200)	100	
MDMK4040T1R5MF V	1.5	±20%	0.065	3,700 (5,400)	3,300 (3,600)	100	
MDMK4040T2R2MF V	2.2	±20%	0.092	3,200 (4,500)	2,500 (2,900)	100	

Absolute maximum voltage: DC25V

(Typ): Reference

● MDMK4040 type [Thickness: 1.2mm max]

Part number	Nominal inductance [μH]	Inductance tolerance	DC Resistance [Ω] (max.)	Rated current ※) [mA]		Measuring frequency [MHz]	Note
				Saturation current Idc1 Max (Typ)	Temperature rise current Idc2 Max (Typ)		
MDMK4040TR68MM V	0.68	±20%	0.029	6,700 (7,800)	5,000 (5,700)	1	
MDMK4040T1R0MM V	1.0	±20%	0.036	5,000 (6,200)	4,500 (5,100)	1	
MDMK4040T1R5MM V	1.5	±20%	0.065	4,500 (5,600)	3,200 (3,600)	1	
MDMK4040T2R2MM V	2.2	±20%	0.079	3,800 (4,500)	2,800 (3,200)	1	
MDMK4040T3R3MM V	3.3	±20%	0.130	3,200 (4,000)	2,200 (2,500)	1	
MDMK4040T4R7MM V	4.7	±20%	0.160	2,500 (3,000)	1,900 (2,200)	1	
MDMK4040T6R8MM V	6.8	±20%	0.230	1,900 (2,200)	1,600 (1,800)	1	
MDMK4040T100MM V	10	±20%	0.330	1,700 (2,000)	1,400 (1,600)	1	

Absolute maximum voltage: DC25V

(Typ): Reference

● MDWK4040 type [Thickness: 2.0mm max]

Part number	Nominal inductance [μH]	Inductance tolerance	DC Resistance [Ω] (max.)	Rated current ※) [mA]		Measuring frequency [MHz]	Note
				Saturation current Idc1 Max (Typ)	Temperature rise current Idc2 Max (Typ)		
MDWK4040TR56NM V	0.56	±20%	0.016	9,000 (13,000)	6,500 (7,500)	1	
MDWK4040TR68MM V	0.68	±20%	0.016	8,000 (12,000)	7,300 (8,300)	1	
MDWK4040T1R0MM V	1.0	±20%	0.027	7,000 (9,400)	5,100 (5,800)	1	
MDWK4040T1R5MM V	1.5	±20%	0.041	7,000 (9,400)	4,100 (4,700)	1	
MDWK4040T2R2MM V	2.2	±20%	0.054	5,400 (7,500)	3,500 (4,000)	1	
MDWK4040T3R3MM V	3.3	±20%	0.075	3,700 (5,200)	3,000 (3,300)	1	
MDWK4040T4R7MM V	4.7	±20%	0.107	3,500 (5,000)	2,500 (2,800)	1	
MDWK4040T6R8MM V	6.8	±20%	0.158	2,900 (4,000)	2,000 (2,300)	1	
MDWK4040T100MM V	10	±20%	0.194	2,200 (3,100)	1,600 (1,900)	1	

Absolute maximum voltage: DC25V

(Typ): Reference

※) The saturation current value (Idc1) is the DC current value having inductance decrease down to 30%. (at 20°C)

※1-1) The temperature rise current value (Idc2) is the DC current value having temperature increase by 40°C, when mounted in FR4 High heat dissipation board (board thickness: 1.0mm copper thickness: 0.035mm, board size: 110 × 30 × 1.0mm, land size: 12.6 × 19.6mm). (at 20°C)

※1-2) The temperature rise current value (Idc2) is the DC current value having temperature increase by 40°C, when mounted in FR4 High heat dissipation board (board thickness: 1.6mm copper thickness: 0.050mm, board size: 100 × 100 × 1.6mm, land size: 14.6 × 43mm). (at 20°C)

※1-3) The temperature rise current value (Idc2) is the DC current value having temperature increase by 40°C, when mounted in FR4 High heat dissipation board (board thickness: 1.6mm copper thickness: 0.050mm, board size: 100 × 100 × 1.6mm, land size: 44.5 × 90mm). (at 20°C)

※) The rated current is the DC current value that satisfies both of current value saturation current value and temperature rise current value.

※1-1) MDKK2020, MDMK2020 type

※1-2) MDKK3030, MDMK3030 type

※1-3) MDMK4040, MDWK4040 type

▶ This catalog contains the typical specification only due to the limitation of space. When you consider the purchase of our products, please check our product specification sheets. For details of each product (characteristics graph, reliability information, precautions for use, and so on), see our website (<http://www.ty-top.com/>).

Derating of Rated Current

MD series

Derating of current is necessary for MD series depending on ambient temperature. Please refer to the chart shown below for appropriate derating of current.

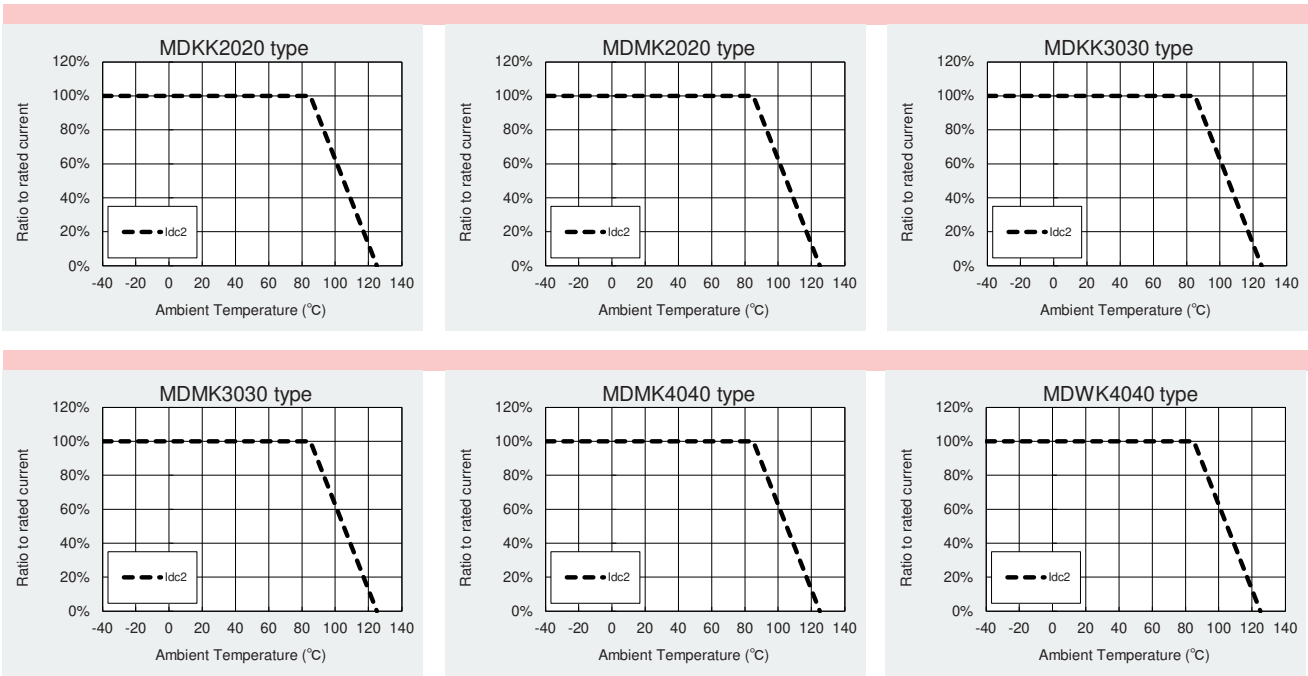

► This catalog contains the typical specification only due to the limitation of space. When you consider the purchase of our products, please check our product specification sheets. For details of each product (characteristics graph, reliability information, precautions for use, and so on), see our website (<http://www.ty-top.com/>).

METAL CORE SMD POWER INDUCTORS (MCOIL™ MD SERIES)

PACKAGING

① Minimum Quantity

Type	Standard Quantity [pcs]
	Tape & Reel
MDKK1616	2500
MDJE2020	2500
MDKK2020	
MDMK2020	
MDKK3030	2000
MDMK3030	
MDJE4040	1000
MDMK4040	
MDWK4040	700
MDPK5050	1000

② Tape Material

● Embossed Tape

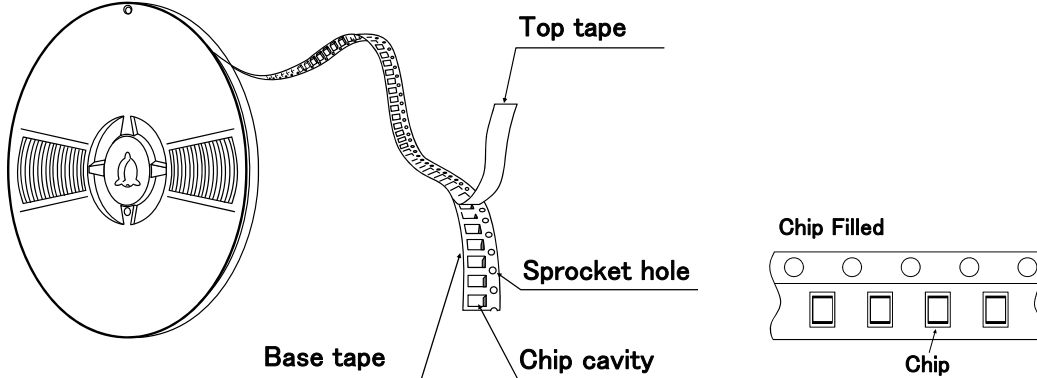

③ Taping dimensions

● Embossed tape 8mm wide (0.315 inches wide)

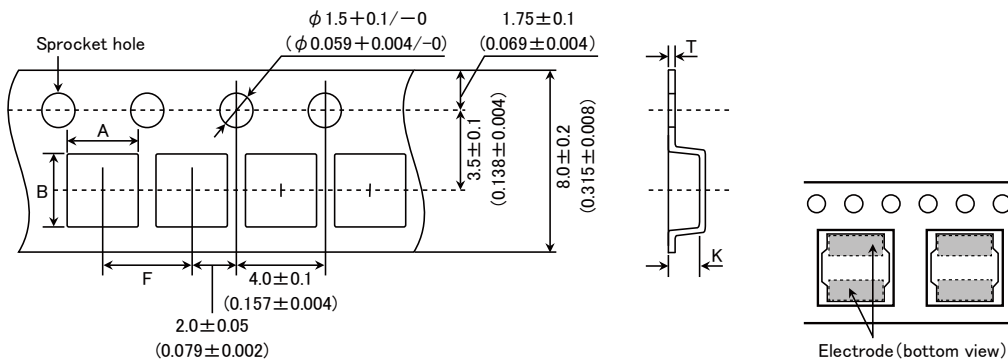

Type	Chip cavity		Insertion pitch	Tape thickness	
	A	B		T	K
MDKK1616	1.79 ± 0.1 (0.071 ± 0.004)	1.79 ± 0.1 (0.071 ± 0.004)	4.0 ± 0.1 (0.157 ± 0.004)	0.25 ± 0.05 (0.010 ± 0.002)	1.1 ± 0.1 (0.043 ± 0.004)
MDJE2020	2.2 ± 0.1 (0.102 ± 0.004)	2.2 ± 0.1 (0.102 ± 0.004)	4.0 ± 0.1 (0.157 ± 0.004)	0.25 ± 0.05 (0.009 ± 0.002)	1.3 ± 0.1 (0.051 ± 0.004)
MDKK2020					
MDMK2020					
MDKK3030	3.2 ± 0.1 (0.126 ± 0.004)	3.2 ± 0.1 (0.126 ± 0.004)	4.0 ± 0.1 (0.157 ± 0.004)	0.3 ± 0.05 (0.012 ± 0.002)	1.4 ± 0.1 (0.055 ± 0.004)
MDMK3030					

Unit: mm (inch)

▶ This catalog contains the typical specification only due to the limitation of space. When you consider the purchase of our products, please check our specification. For details of each product (characteristics graph, reliability information, precautions for use, and so on), see our Web site (<http://www.ty-top.com/>).

● Embossed tape 12mm wide (0.47 inches wide)

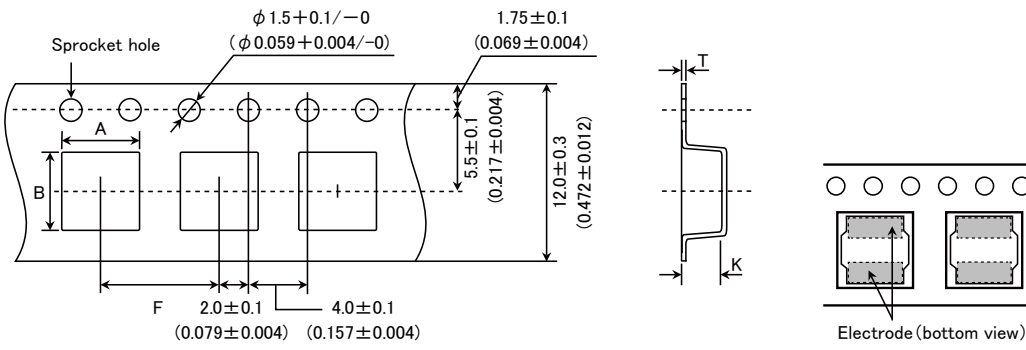

Type	Chip cavity		Insertion pitch	Tape thickness	
	A	B		T	K
MDJE4040	4.3±0.1 (0.169±0.004)	4.3±0.1 (0.169±0.004)	8.0±0.1 (0.315±0.004)	0.3±0.05 (0.012±0.002)	1.6±0.1 (0.063±0.004)
MDMK4040	4.3±0.1 (0.169±0.004)	4.3±0.1 (0.169±0.004)	8.0±0.1 (0.315±0.004)	0.3±0.05 (0.012±0.002)	2.3±0.1 (0.091±0.004)
MDWK4040	4.3±0.1 (0.169±0.004)	4.3±0.1 (0.169±0.004)	8.0±0.1 (0.315±0.004)	0.3±0.05 (0.012±0.002)	2.3±0.1 (0.091±0.004)
MDPK5050	5.25±0.1 (0.207±0.004)	5.25±0.1 (0.207±0.004)	8.0±0.1 (0.315±0.004)	0.3±0.1 (0.012±0.004)	1.6±0.1 (0.063±0.004)

Unit: mm (inch)

④ Leader and Blank portion

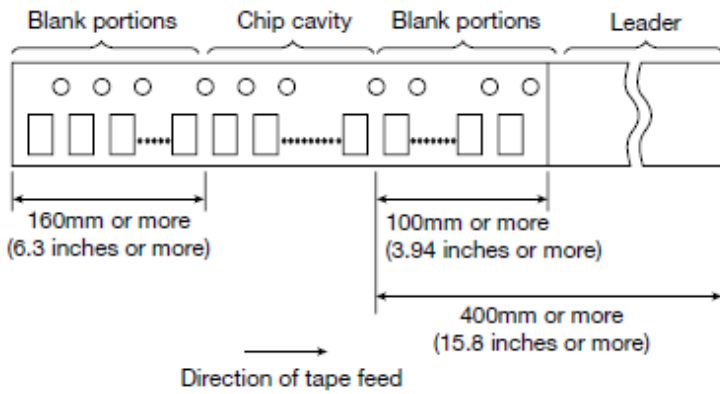

► This catalog contains the typical specification only due to the limitation of space. When you consider the purchase of our products, please check our specification. For details of each product (characteristics graph, reliability information, precautions for use, and so on), see our Web site (<http://www.ty-top.com/>).

⑤ Reel size

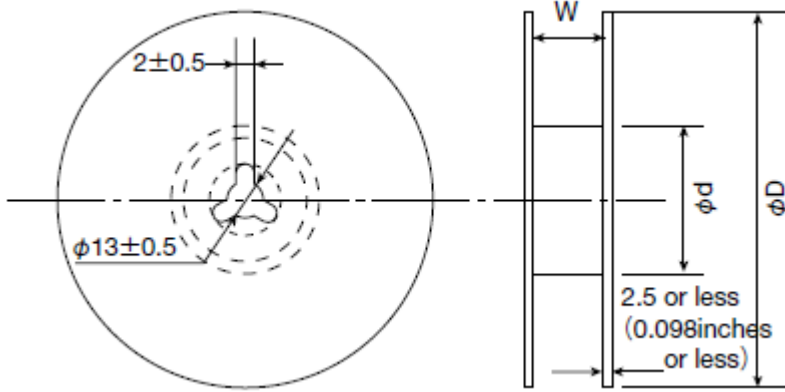

Type	Reel size (Reference values)		
	ϕD	ϕd	W
MDKK1616	180 ± 0.5 (7.087 ± 0.019)	60 ± 1.0 (2.36 ± 0.04)	10.0 ± 1.5 (0.394 ± 0.059)
MDJE2020			
MDKK2020			
MDMK2020			
MDKK3030	180 ± 3.0 (7.087 ± 0.118)	60 ± 2.0 (2.36 ± 0.08)	14.0 ± 1.5 (0.551 ± 0.059)
MDMK3030			
MDJE4040			
MDMK4040			
MDWK4040	180 ± 3.0 (7.087 ± 0.118)	60 ± 2.0 (2.36 ± 0.08)	14.0 ± 1.5 (0.551 ± 0.059)
MDPK5050			

Unit : mm (inch)

⑥ Top Tape Strength

Top tape strength

Type	Peel-off strength
MDKK1616	0.1N ~ 1.0N
MDJE2020	
MDKK2020	
MDMK2020	
MDKK3030	0.1N ~ 1.3N
MDMK3030	
MDJE4040	
MDMK4040	
MDWK4040	0.1N ~ 1.3N
MDPK5050	

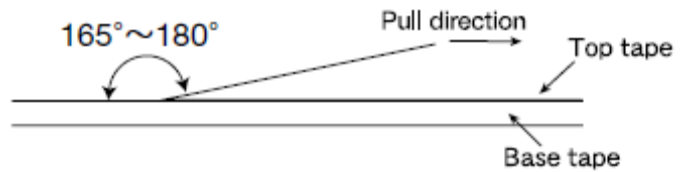

METAL CORE SMD POWER INDUCTORS (MCOIL™ MD SERIES)

RELIABILITY DATA

1. Operating Temperature Range		
Specified Value	MD series	-40~+125°C (Including self-generated heat)
Test Methods and Remarks	Including self-generated heat	
2. Storage Temperature Range		
Specified Value	MD series	-40~+85°C
Test Methods and Remarks	-5 to 40°C for the product with taping.	
3. Rated current		
Specified Value	MD series	Within the specified tolerance
4. Inductance		
Specified Value	MD series	Within the specified tolerance
Test Methods and Remarks	MDKK2020, MDMK2020, MDKK3030, MDMK3030, MDMK4040M, MDWK4040 Measuring equipment : LCR Meter (HP 4285A or equivalent) Measuring frequency : 1MHz 1V MDMK4040F Measuring equipment : LCR Meter (HP 4285A or equivalent) Measuring frequency : 100kHz 1V	
5. DC Resistance		
Specified Value	MD series	Within the specified tolerance
Test Methods and Remarks	Measuring equipment : DC ohmmeter (HIOKI 3227 or equivalent)	
6. Self resonance frequency		
Specified Value	MD series	—
7. Temperature characteristic		
Specified Value	MD series	Inductance change : Within ±10%
Test Methods and Remarks	Measurement of inductance shall be taken at temperature range within -40°C~+125°C. With reference to inductance value at +20°C., change rate shall be calculated.	
8. Resistance to flexure of substrate		
Specified Value	MD series	No damage
Test Methods and Remarks	The test samples shall be soldered to the test board by the reflow. As illustrated below, apply force in the direction of the arrow indicating until deflection of the test board reaches to 2 mm. Test board size : 100 × 40 × 1.6 mm Test board material : glass epoxy-resin Solder cream thickness : 0.10 mm	

9. Insulation resistance : between wires

Specified Value	MD series	—
-----------------	-----------	---

10. Insulation resistance : between wire and core

Specified Value	MD series	—
-----------------	-----------	---

▶ This catalog contains the typical specification only due to the limitation of space. When you consider the purchase of our products, please check our specification. For details of each product (characteristics graph, reliability information, precautions for use, and so on), see our Web site (<http://www.ty-top.com/>).

11. Withstanding voltage : between wire and core																				
Specified Value	MD series	—																		
12. Adhesion of terminal electrode																				
Specified Value	MD series	Shall not come off PC board																		
Test Methods and Remarks	The test samples shall be soldered to the test board by the reflow. Applied force : 10N to X and Y directions. Duration : 5s. Solder cream thickness : 0.1mm.																			
13. Resistance to vibration																				
Specified Value	MD series	Inductance change : Within $\pm 10\%$ No significant abnormality in appearance.																		
Test Methods and Remarks	The test samples shall be soldered to the test board by the reflow. Then it shall be submitted to below test conditions. <table border="1" style="margin-left: 20px;"> <tr> <td>Frequency Range</td> <td colspan="2">10~55Hz</td> </tr> <tr> <td>Total Amplitude</td> <td colspan="2">1.5mm (May not exceed acceleration 196m/s²)</td> </tr> <tr> <td>Sweeping Method</td> <td colspan="2">10Hz to 55Hz to 10Hz for 1min.</td> </tr> <tr> <td rowspan="3">Time</td> <td>X</td> <td rowspan="3">For 2 hours on each X, Y, and Z axis.</td> </tr> <tr> <td>Y</td> </tr> <tr> <td>Z</td> </tr> </table> Recovery : At least 2hrs of recovery under the standard condition after the test, followed by the measurement within 48hrs.		Frequency Range	10~55Hz		Total Amplitude	1.5mm (May not exceed acceleration 196m/s ²)		Sweeping Method	10Hz to 55Hz to 10Hz for 1min.		Time	X	For 2 hours on each X, Y, and Z axis.	Y	Z				
Frequency Range	10~55Hz																			
Total Amplitude	1.5mm (May not exceed acceleration 196m/s ²)																			
Sweeping Method	10Hz to 55Hz to 10Hz for 1min.																			
Time	X	For 2 hours on each X, Y, and Z axis.																		
	Y																			
	Z																			
14. Solderability																				
Specified Value	MD series	At least 90% of surface of terminal electrode is covered by new solder.																		
Test Methods and Remarks	The test samples shall be dipped in flux, and then immersed in molten solder as shown in below table. Flux : Methanol solution containing rosin 25%. <table border="1" style="margin-left: 20px;"> <tr> <td>Solder Temperature</td> <td>245\pm5$^{\circ}$C</td> </tr> <tr> <td>Time</td> <td>5\pm1.0 sec.</td> </tr> </table> ※Immersion depth : All sides of mounting terminal shall be immersed.		Solder Temperature	245 \pm 5 $^{\circ}$ C	Time	5 \pm 1.0 sec.														
Solder Temperature	245 \pm 5 $^{\circ}$ C																			
Time	5 \pm 1.0 sec.																			
15. Resistance to soldering heat																				
Specified Value	MD series	Inductance change : Within $\pm 10\%$ No significant abnormality in appearance.																		
Test Methods and Remarks	The test sample shall be exposed to reflow oven at 230 \pm 5 $^{\circ}$ C for 40 seconds, with peak temperature at 260 \pm 5 $^{\circ}$ C for 5 seconds, 2 times. Test board material : glass epoxy-resin Test board thickness : 1.0mm																			
16. Thermal shock																				
Specified Value	MD series	Inductance change : Within $\pm 10\%$ No significant abnormality in appearance.																		
Test Methods and Remarks	The test samples shall be soldered to the test board by the reflow. The test samples shall be placed at specified temperature for specified time by step 1 to step 4 as shown in below table in sequence. The temperature cycle shall be repeated 1000 cycles. <table border="1" style="margin-left: 20px;"> <thead> <tr> <th colspan="3">Conditions of 1 cycle</th> </tr> <tr> <th>Step</th> <th>Temperature ($^{\circ}$C)</th> <th>Duration (min)</th> </tr> </thead> <tbody> <tr> <td>1</td> <td>-40\pm3</td> <td>30\pm3</td> </tr> <tr> <td>2</td> <td>Room temperature</td> <td>Within 3</td> </tr> <tr> <td>3</td> <td>+85\pm2</td> <td>30\pm3</td> </tr> <tr> <td>4</td> <td>Room temperature</td> <td>Within 3</td> </tr> </tbody> </table>		Conditions of 1 cycle			Step	Temperature ($^{\circ}$ C)	Duration (min)	1	-40 \pm 3	30 \pm 3	2	Room temperature	Within 3	3	+85 \pm 2	30 \pm 3	4	Room temperature	Within 3
Conditions of 1 cycle																				
Step	Temperature ($^{\circ}$ C)	Duration (min)																		
1	-40 \pm 3	30 \pm 3																		
2	Room temperature	Within 3																		
3	+85 \pm 2	30 \pm 3																		
4	Room temperature	Within 3																		
17. Damp heat																				
Specified Value	MD series	Inductance change : Within $\pm 10\%$ No significant abnormality in appearance.																		
Test Methods and Remarks	The test samples shall be soldered to the test board by the reflow. The test samples shall be placed in thermostatic oven set at specified temperature and humidity as shown in below table. <table border="1" style="margin-left: 20px;"> <tr> <td>Temperature</td> <td>60\pm2$^{\circ}$C</td> </tr> <tr> <td>Humidity</td> <td>90~95%RH</td> </tr> <tr> <td>Time</td> <td>1000+24/-0 hour</td> </tr> </table>		Temperature	60 \pm 2 $^{\circ}$ C	Humidity	90~95%RH	Time	1000+24/-0 hour												
Temperature	60 \pm 2 $^{\circ}$ C																			
Humidity	90~95%RH																			
Time	1000+24/-0 hour																			

18. Loading under damp heat		
Specified Value	MD series	Inductance change : Within $\pm 10\%$ No significant abnormality in appearance.
Test Methods and Remarks	The test samples shall be soldered to the test board by the reflow. The test samples shall be placed in thermostatic oven set at specified temperature and humidity and applied the rated current continuously as shown in below table.	
	Temperature	$60 \pm 2^\circ\text{C}$
	Humidity	90~95%RH
	Applied current	Rated current
	Time	1000+24/-0 hour
19. Low temperature life test		
Specified Value	MD series	Inductance change : Within $\pm 10\%$ No significant abnormality in appearance.
Test Methods and Remarks	The test samples shall be soldered to the test board by the reflow. After that, the test samples shall be placed at test conditions as shown in below table.	
	Temperature	$-40 \pm 2^\circ\text{C}$
	Time	1000+24/-0 hour
20. High temperature life test		
Specified Value	MD series	—
21. Loading at high temperature life test		
Specified Value	MD series	Inductance change : Within $\pm 10\%$ No significant abnormality in appearance.
Test Methods and Remarks	The test samples shall be soldered to the test board by the reflow. The test samples shall be placed in thermostatic oven set at specified temperature and applied the rated current continuously as shown in below table.	
	Temperature	$85 \pm 2^\circ\text{C}$
	Applied current	Rated current
	Time	1000+24/-0 hour
22. Standard condition		
Specified Value	MD series	Standard test condition : Unless otherwise specified, temperature is $20 \pm 15^\circ\text{C}$ and $65 \pm 20\%$ of relative humidity. When there is any question concerning measurement result: In order to provide correlation data, the test shall be condition of $20 \pm 2^\circ\text{C}$ of temperature, $65 \pm 5\%$ relative humidity. Inductance is in accordance with our measured value.

METAL CORE SMD POWER INDUCTORS (MCOIL™ MD SERIES)

PRECAUTIONS

1. Circuit Design	
Precautions	<p>◆ Operating environment</p> <p>1. The products listed in this catalogue are intended for use in general electronic equipment (e.g., AV equipment, OA equipment, home electric appliances, office equipment, information and communication equipment), general medical equipment, industrial equipment, and automotive interior applications, etc.</p> <p>Please be sure to contact TAIYO YUDEN for further information before using the products for any equipment which may directly cause loss of human life or bodily injury (e.g., specially controlled medical equipment, transportation equipment including, without limitation, automotive powertrain control system, train control system, and ship control system, traffic signal equipment).</p> <p>Please do not incorporate our products into any equipment requiring high levels of safety and/or reliability (e.g., aerospace equipment, aviation equipment, nuclear control equipment, undersea equipment, military equipment, etc.).</p>
2. PCB Design	
Precautions	<p>◆ Land pattern design</p> <p>1. Please refer to a recommended land pattern.</p>
Technical considerations	<p>◆ Land pattern design</p> <p>Surface Mounting</p> <ul style="list-style-type: none"> • Mounting and soldering conditions should be checked beforehand. • Applicable soldering process to this products is reflow soldering only.
3. Considerations for automatic placement	
Precautions	<p>◆ Adjustment of mounting machine</p> <p>1. Excessive impact load should not be imposed on the products when mounting onto the PC boards.</p> <p>2. Mounting and soldering conditions should be checked beforehand.</p>
Technical considerations	<p>◆ Adjustment of mounting machine</p> <p>1. When installing products, care should be taken not to apply distortion stress as it may deform the products.</p>
4. Soldering	
Precautions	<p>◆ Reflow soldering</p> <p>1. Please contact any of our offices for a reflow soldering, and refer to the recommended condition specified.</p> <p>2. The product shall be used reflow soldering only.</p> <p>3. Please do not add any stress to a product until it returns in normal temperature after reflow soldering.</p> <p>◆ Lead free soldering</p> <p>1. When using products with lead free soldering, we request to use them after confirming adhesion, temperature of resistance to soldering heat, soldering etc sufficiently.</p> <p>◆ Recommended conditions for using a soldering iron (NR10050 Type)</p> <ul style="list-style-type: none"> • Put the soldering iron on the land-pattern. • Soldering iron's temperature – Below 350°C • Duration – 3 seconds or less • The soldering iron should not directly touch the inductor.
Technical considerations	<p>◆ Reflow soldering</p> <p>1. If products are used beyond the range of the recommended conditions, heat stresses may deform the products, and consequently degrade the reliability of the products.</p> <p>• NR30/40/50/60/80, NRV20/30, NRH24/30, NRS20/40/50/60/80 Type, NR10050 Type, NS101/125 Type</p> <p>Recommended reflow condition (Pb free solder)</p>
5. Cleaning	
Precautions	<p>◆ Cleaning conditions</p> <p>1. Washing by supersonic waves shall be avoided.</p>
Technical considerations	<p>◆ Cleaning conditions</p> <p>1. If washed by supersonic waves, the products might be broken.</p>

▶ This catalog contains the typical specification only due to the limitation of space. When you consider the purchase of our products, please check our specification. For details of each product (characteristics graph, reliability information, precautions for use, and so on), see our Web site (<http://www.ty-top.com/>).

6. Handling	
Precautions	<ul style="list-style-type: none"> ◆ Handling <ol style="list-style-type: none"> 1. Keep the product away from all magnets and magnetic objects. ◆ Breakaway PC boards (splitting along perforations) <ol style="list-style-type: none"> 1. When splitting the PC board after mounting product, care should be taken not to give any stresses of deflection or twisting to the board. 2. Board separation should not be done manually, but by using the appropriate devices. ◆ Mechanical considerations <ol style="list-style-type: none"> 1. Please do not give the product any excessive mechanical shocks. 2. Please do not add any shock and power to a product in transportation. ◆ Pick-up pressure <ol style="list-style-type: none"> 1. Please do not push to add any pressure to a winding part. Please do not give any shock and push into a ferrite core exposure part. ◆ Packing <ol style="list-style-type: none"> 1. Please avoid accumulation of a packing box as much as possible. ◆ Board mounting <ol style="list-style-type: none"> 1. There shall be no pattern or via between terminals at the bottom of product. 2. Components which are located in peripheral of product shall not make contact with surface (top, side) of product.
Technical considerations	<ul style="list-style-type: none"> ◆ Handling <ol style="list-style-type: none"> 1. There is a case that a characteristic varies with magnetic influence. ◆ Breakaway PC boards (splitting along perforations) <ol style="list-style-type: none"> 1. The position of the product on PCBs shall be carefully considered to minimize the stress caused from splitting of the PCBs. ◆ Mechanical considerations <ol style="list-style-type: none"> 1. There is a case to be damaged by a mechanical shock. 2. There is a case to be broken by the handling in transportation. ◆ Pick-up pressure <ol style="list-style-type: none"> 1. Damage and a characteristic can vary with an excessive shock or stress. ◆ Packing <ol style="list-style-type: none"> 1. If packing boxes are accumulated, that could cause a deformation on packing tapes or a damage on the products. ◆ Board mounting <ol style="list-style-type: none"> 1. If there is pattern or via between terminals at the bottom of product, it may cause characteristics change. 2. If components which are located in peripheral of product make contact with surface (top, side) of product, it may cause damage or characteristics change.
7. Storage conditions	
Precautions	<ul style="list-style-type: none"> ◆ Storage <ol style="list-style-type: none"> 1. To maintain the solderability of terminal electrodes and to keep the packing material in good condition, temperature and humidity in the storage area should be controlled. <ul style="list-style-type: none"> • Recommended conditions <ul style="list-style-type: none"> Ambient temperature : $-5\sim 40^{\circ}\text{C}$ Humidity : Below 70% RH • The ambient temperature must be kept below 30°C. Even under ideal storage conditions, solderability of products electrodes may decrease as time passes. For this reason, product should be used within 6 months from the time of delivery. In case of storage over 6 months, solderability shall be checked before actual usage.
Technical considerations	<ul style="list-style-type: none"> ◆ Storage <ol style="list-style-type: none"> 1. Under a high temperature and humidity environment, problems such as reduced solderability caused by oxidation of terminal electrodes and deterioration of taping/packaging materials may take place.